

Quiet-Duct Conic-Flow® Silencers

Section 15000 Specifications

1.01 General

- A. Furnish and install "Conic-Flow" (tubular) silencers of the types and sizes shown on the plans and/or listed in the schedule. Silencers shall be the product of IAC Acoustics. Any specification change must be submitted in writing and approved by the Architect/Engineer, in writing, at least 10 days prior to the bid due-date.

2.01 Materials

- A. Outer casings of tubular silencers shall be made of type #G-90 lock-former-quality galvanized steel in the following gauges:

Outside Diamer, In.	Metal Gauge	Outside Diameter, In.	Metal Gauge
12-36	22	38-60	18

- B. Interior construction of tubular silencers shall be compatible with the respective outside casing.
- C. Filler material shall be inorganic glass fiber of a proper density to obtain the specified acoustic performance and be packed under not less than 5% compression to eliminate voids due to vibration and settling. Material shall be inert, vermin- and moisture-proof.
- D. Combustion ratings for the silencer acoustic fill shall be not greater than the following when tested to ASTM E 84, NFPA Standard 255, or UL No. 723:

Flamespread Classification	20
Smoke Development Rating.....	20

3.01 Construction

- A. Units shall be constructed in accordance with the ASHRAE Guide recommendations for high pressure duct work. Seams shall be lock formed and mastic filled. Rectangular casing seams shall be in the corners of the silencer shell to provide maximum unit strength and rigidity. Interior partitions shall be fabricated from single-piece, margin-perforated sheets and shall have die-formed entrance and exit shapes so as to provide the maximum aerodynamic efficiency and minimum self-noise characteristics in the sound attenuator. Blunt noses or squared off partitions will not be accepted.
- B. Interior partitions for tubular silencers shall be secured with galvanized steel radial mounting brackets welded to the partition and the outer casing. The radial brackets shall be installed full length and at 120 degree angles to each other to assure uniform spacing for consistent aerodynamic and acoustic performance.
- C. Sound attenuating units shall not fail structurally when subjected to a differential air pressure of 8 inches water gauge from inside to outside the casing. Airtight construction shall be provided by use of a duct sealing compound on the job-site material and labor furnished by the contractor.

4.01 Acoustic Performance

- A. All silencer ratings shall be determined in a duct-to-reverberant room test facility which provides for airflow in both directions through the test silencer in accordance with ASTM Specification E477-99. The test facility shall be NVLAP accredited for the ASTM E477-99 test standard. Data from a non-accredited laboratory will not be acceptable. The test set-up and procedure shall be such that all effects due to end reflection, directivity, flanking transmission, standing waves and test chamber sound absorption are eliminated.

Acoustic ratings shall include Dynamic Insertion Loss (DIL) and Self-Noise (SN) Power Levels both for FORWARD FLOW (air and noise in same direction) and REVERSE FLOW (air and noise in opposite directions) with airflow of at least 2000 fpm entering face velocity. Data for rectangular and tubular type silencers shall be presented for tests conducted using silencers no smaller than the following cross-sections:

Rectangular, inch: 24 x 24, 24 x 30, or 24 x 36
 Tubular, inch: 12, 24, 36 and 48

5.01 Aerodynamic Performance

- A. Static pressure loss of silencers shall not exceed those listed in the silencer schedule as the airflow indicates. Airflow measurements shall be made in accordance with ASTM specification E477-99 and applicable portions of ASME, AMCA, and ADC airflow test codes. Tests shall be reported on the identical units for which acoustic data is presented.

6.01 Certification

- A. With submittals, the manufacturer shall supply certified test data on Dynamic Insertion Loss, Self-Noise Power Levels, and Aerodynamic Performance for Reverse and Forward Flow test conditions. Test data shall be for a standard product. All rating tests shall be conducted in the same facility, shall utilize the same silencer, and shall be open to inspection upon request from the Architect/Engineer.

7.01 Duct Transitions

- A. When transitions are required to adapt silencer dimensions to connecting duct work they shall be furnished by the installing contractor.

Low Frequency Conic-Flow® Silencers

Type: NS

Forward & Reverse Flow Ratings

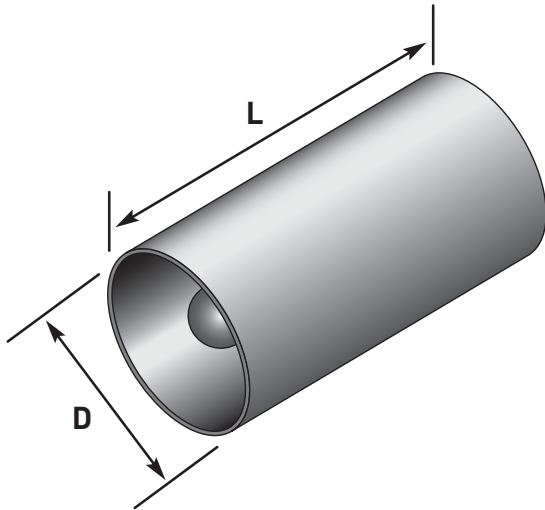

The IAC Type NS Conic-Flow Silencers have been rated with procedures certified in accordance with applicable portions of ASTM E477. All Dynamic Insertion Loss and Self-Noise Acoustic Performance Data were obtained in a NVLAP accredited Aero-Acoustic Laboratory using the duct-to-room reverberant test facility **with air flowing through the silencers.**

Designating Silencers

Model: 12 NS 36

Type: NS **Diameter:** 12" **Length:** 36"

Table I: Dynamic Insertion Loss (DIL) Ratings: Forward (+) / Reverse (-) Flow

IAC Model	Octave Band	1	2	3	4	5	6	7	8
	Hz	63	125	250	500	1K	2K	4K	8K
	Face Velocity, fpm	Dynamic Insertion Loss, dB							
12NS	-4000	3	4	9	15	24	21	13	8
	-2000	3	4	9	14	24	21	13	8
	0	3	4	9	14	22	21	14	10
	2000	3	4	9	14	19	21	14	12
	4000	3	4	9	14	17	21	14	12
24NS	-4000	4	11	16	22	25	19	11	10
	-2000	4	10	15	20	24	21	12	11
	0	4	10	15	19	24	21	12	12
	2000	4	10	14	18	23	21	12	12
	4000	4	9	13	17	23	21	12	12
36NS	-4000	6	13	17	23	23	15	10	8
	-2000	6	13	17	22	23	16	11	9
	0	6	13	17	21	23	17	11	10
	2000	6	13	17	20	22	17	11	10
	4000	6	12	16	19	22	17	11	10
48NS	-4000	7	15	19	25	22	11	9	7
	-2000	7	15	19	23	20	12	10	8
	0	7	15	19	23	20	12	10	8
	2000	7	15	19	23	20	12	10	8
	4000	7	15	19	22	20	12	10	8
60NS	-4000	10	17	21	23	19	8	7	6
	-2000	10	17	20	23	18	9	8	7
	0	10	17	20	23	18	10	9	8
	2000	10	17	20	22	17	10	9	8
	4000	9	16	19	22	17	10	10	9

(+) Forward Flow / (-) Reverse Flow. Aero-acoustic performance data based on NVLAP accredited laboratory tests conducted in strict accordance with ASTM E477-99. Contact IAC if attenuation in excess of 50 dB is required.

Table II: Weights & Measures

Model	Duct Diameter, Inches	12	14	16	18	20	22	24	26
	Silencer Length, Inches	40	46	52	58	64	72	78	84
NS	Weight, lb.	40	55	75	95	110	125	140	200

Model	Duct Diameter, Inches	28	30	32	36	40	44	48	60
	Silencer Length, Inches	90	98	104	118	130	144	156	196
NS	Weight, lb.	255	310	365	425	480	565	650	1640

Table III: Aerodynamic Performance

IAC Model	L/Ft	Static Pressure Drop, i.w.g.																
		All Sizes	0.05	0.08	0.10	0.13	0.17	0.21	0.25	0.30	0.36	0.41	0.47	0.54	0.61	0.68	0.76	0.84
NS																		
Silencer Face Velocity, fpm		1000	1200	1400	1600	1800	2000	2200	2400	2600	2800	3000	3200	3400	3600	3800	4000	

Table IV: Self-Noise Power Levels, dB re: 10-12 Watts

IAC Model	Octave Band	1	2	3	4	5	6	7	8
	Hz	63	125	250	500	1K	2K	4K	8K
	Silencer Face Velocity, fpm								
NS (all sizes)	-3000	59	56	55	57	57	59	55	50
	-2000	51	48	47	48	49	51	44	36
	-1000	37	34	33	33	35	38	26	20
	1000	44	37	33	32	35	31	20	20
	2000	56	48	45	45	47	46	38	28
	3000	63	54	52	53	54	55	50	43

(+) Forward Flow / (-) Reverse Flow. Aero-acoustic performance data based on NVLAP accredited laboratory tests conducted in strict accordance with ASTM E477-99.

TAKE NOTE!

- Silencer Face Area is the cross-sectional area at the silencer entrance
- Face Velocity is the CFM of airflow divided by the Face Area (in sq. ft.)
- Pressure Drop for any velocity can be calculated from this equation:
 $PD = (\text{Actual FV}/\text{Catalog FV})^2 \times (\text{Catalog PD})$
- Self Noise values shown are for a four-square-foot face area silencer
- For each doubling of the face area add 3 dB to the self-noise values listed
- For each halving of the face area subtract 3 dB from the self-noise values listed
- Weights and measures are listed for limited number of available sizes