

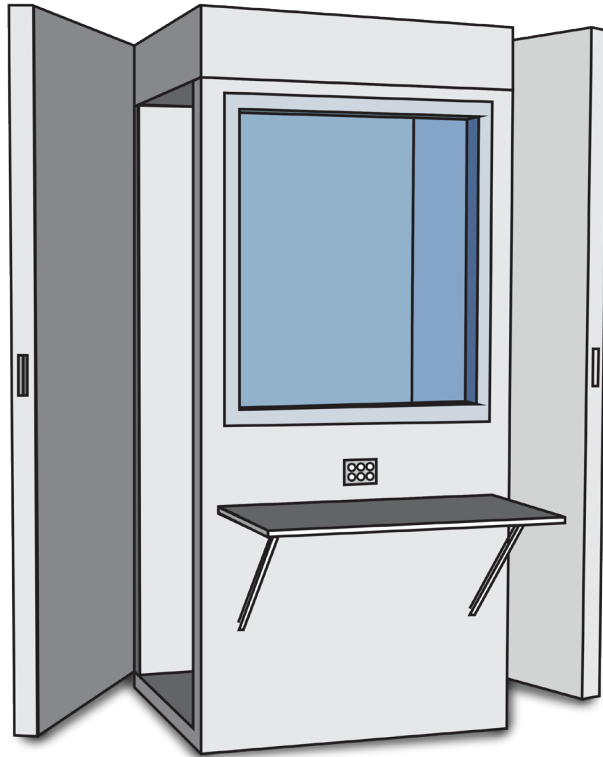

# Data Sheet

## 252 Series Mini Sound Shelter



The **252 Series Mini Sound Shelter** design is engineered to allow flexibility in any environment. The 252 Series can be quickly transformed to achieve a right or left hand configuration, without any disassembly of components, by any staff member without any tools.

### Ideally suited for:

- Industrial — Monitoring Audiometry
- Public School — Identification Audiometry
- Speech Audiometry (through earphones)
- Psychological Data Recording
- Hearing Health Professionals
- Mobile Test Vans

### Equipped with:

- Noise-Lock® magnetic-seal doors for safety
- Tranquil-Air® silent forced ventilation system
- Outside mounted shelf (16" x 32")
- Casters for ready positioning or repositioning of booth

### Typical Plan

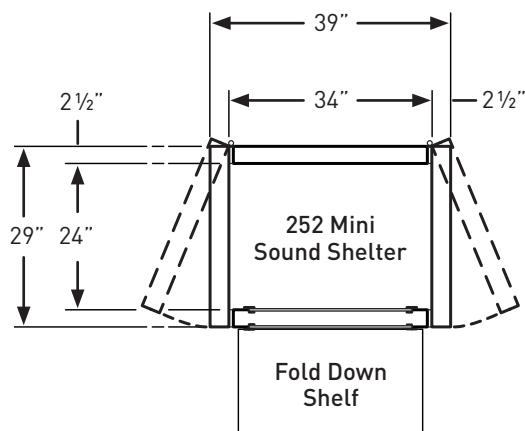

### Ready to go to work:

- Shipped fully equipped and assembled — passes through any normal 30" (762 mm) wide door
- Inside Dimension: 24" wide x 34" deep x 66" high (610 mm x 864 mm x 1676 mm)
- Outside Dimension: 29" wide x 39" deep x 75.5" high (737 mm x 991 mm x 1905 mm)
- Floor area is less than 8 sq. ft. (0.74 sq m)
- Net weight: 650 lbs. (295 kg)
- Shipping weight: 710 lbs. (322kg)





# Data Sheet

## 252 Series Mini Sound Shelter



### Net Weight:

650 lbs.

### Panel Construction:

2 ½" thick Noishield® panels

### Largest Panel Size:

2'-10" wide x 5'-6" long x 2 ½" thick  
Customer to ensure adequate site access

### Interior Surfaces:

22ga. galvanized perforated steel

### Exterior Surfaces:

14ga. cold rolled solid steel

### Floor Interior Surface:

11ga. hot rolled steel

### Finish:

Textured powder coated

### Door:

(2) 2' wide x 5'-6" high (clear opening) doors supported on (2) architectural heavy duty butt hinges integrally mounted within the door leaf and panel frame

### Note:

- Self-aligning magnetic compression seals are mounted on the top and sides of the door leaf
- A self-adjusting drag seal is supplied for the bottom of the door

### Window:

(1) 2' wide x 2'-6" high aluminum frame with double glazed ¼" thick laminated safety glass

### Shelf:

(1) 1'-4" wide x 2'-8" deep externally mounted shelf for audiometer

### Electrical:

- Switch mounted on lighting fixture inside the room operates the fan and light
- (1) 10' long drop cord provided for connection to power

### Note:

- Booth is factory UL certified and labeled

### Audiometric Jack Panel:

Completely pre-wired, flush-mounted jack panel consisting of (6) switchcraft 3-wire phone type jacks

### Booth Options:

#### Ventilation:

Ceiling panel contains an all-in-one forced ventilation system and intake and exhaust silencers

#### Color:

"Khaki" standard or choice of (9) standard colors

#### Floor Covering:

Industrial nylon carpet, to match paint color selection with 3/8" thick underlayment and 2-1/2" H black cove base molding included

### Noise Reduction:

Octave Band Center Frequency, (Hz)	125	250	500	1K	2K	4K	8K
Noise Reduction, dB	18	32	38	44	51	52	50

### Note:

Noise reduction is defined as the measured difference between the sound pressure levels outside and inside the booth

### Optional Equipment:

- Vibration isolators are available where structure-borne noise is a problem
- Intercom systems

### Site Requirements:

- Customer to provide a finished floor which is within +/- ¼" of level in 10 non-cumulative feet
- 4" minimum clearance is required between the exterior of testing booth and host facility walls/ceiling

